

Question 3.1:

The storage battery of a car has an emf of 12 V. If the internal resistance of the battery is 0.4Ω , what is the maximum current that can be drawn from the battery?

Answer

Emf of the battery, $E = 12\text{ V}$

Internal resistance of the battery, $r = 0.4\ \Omega$

Maximum current drawn from the battery = I

According to Ohm's law,

$$E = Ir$$

$$I = \frac{E}{r}$$
$$= \frac{12}{0.4} = 30\text{ A}$$

The maximum current drawn from the given battery is 30 A.

Question 3.2:

A battery of emf 10 V and internal resistance $3\ \Omega$ is connected to a resistor. If the current in the circuit is 0.5 A, what is the resistance of the resistor? What is the terminal voltage of the battery when the circuit is closed?

Answer

Emf of the battery, $E = 10\text{ V}$

Internal resistance of the battery, $r = 3\ \Omega$

Current in the circuit, $I = 0.5\text{ A}$

Resistance of the resistor = R

The relation for current using Ohm's law is,

$$I = \frac{E}{R+r}$$
$$R+r = \frac{E}{I}$$
$$= \frac{10}{0.5} = 20\ \Omega$$

$$\therefore R = 20 - 3 = 17\ \Omega$$

Terminal voltage of the resistor = V

According to Ohm's law,

$$\begin{aligned}V &= IR \\ &= 0.5 \times 17 \\ &= 8.5 \text{ V}\end{aligned}$$

Therefore, the resistance of the resistor is 17Ω and the terminal voltage is 8.5 V .

Question 3.3:

(a) Three resistors 1Ω , 2Ω , and 3Ω are combined in series. What is the total resistance of the combination?

(b) If the combination is connected to a battery of emf 12 V and negligible internal resistance, obtain the potential drop across each resistor.

Answer

(a) Three resistors of resistances 1Ω , 2Ω , and 3Ω are combined in series. Total resistance of the combination is given by the algebraic sum of individual resistances.

$$\text{Total resistance} = 1 + 2 + 3 = 6 \Omega$$

(b) Current flowing through the circuit = I

Emf of the battery, $E = 12 \text{ V}$

Total resistance of the circuit, $R = 6 \Omega$

The relation for current using Ohm's law is,

$$\begin{aligned}I &= \frac{E}{R} \\ &= \frac{12}{6} = 2 \text{ A}\end{aligned}$$

Potential drop across 1Ω resistor = V_1

From Ohm's law, the value of V_1 can be obtained as

$$V_1 = 2 \times 1 = 2 \text{ V} \dots \text{(i)}$$

Potential drop across 2Ω resistor = V_2

Again, from Ohm's law, the value of V_2 can be obtained as

$$V_2 = 2 \times 2 = 4 \text{ V} \dots \text{(ii)}$$

Potential drop across 3Ω resistor = V_3

Again, from Ohm's law, the value of V_3 can be obtained as

$$V_3 = 2 \times 3 = 6 \text{ V} \dots \text{(iii)}$$

Therefore, the potential drop across 1 Ω , 2 Ω , and 3 Ω resistors are 2 V, 4 V, and 6 V respectively.

Question 3.4:

(a) Three resistors 2 Ω , 4 Ω and 5 Ω are combined in parallel. What is the total resistance of the combination?

(b) If the combination is connected to a battery of emf 20 V and negligible internal resistance, determine the current through each resistor, and the total current drawn from the battery.

Answer

(a) There are three resistors of resistances,

$$R_1 = 2 \Omega, R_2 = 4 \Omega, \text{ and } R_3 = 5 \Omega$$

They are connected in parallel. Hence, total resistance (R) of the combination is given by,

$$\begin{aligned} \frac{1}{R} &= \frac{1}{R_1} + \frac{1}{R_2} + \frac{1}{R_3} \\ &= \frac{1}{2} + \frac{1}{4} + \frac{1}{5} = \frac{10+5+4}{20} = \frac{19}{20} \\ \therefore R &= \frac{20}{19} \Omega \end{aligned}$$

Therefore, total resistance of the combination is $\frac{20}{19} \Omega$.

(b) Emf of the battery, $V = 20$ V

Current (I_1) flowing through resistor R_1 is given by,

$$\begin{aligned} I_1 &= \frac{V}{R_1} \\ &= \frac{20}{2} = 10 \text{ A} \end{aligned}$$

Current (I_2) flowing through resistor R_2 is given by,

$$\begin{aligned} I_2 &= \frac{V}{R_2} \\ &= \frac{20}{4} = 5 \text{ A} \end{aligned}$$

Current (I_3) flowing through resistor R_3 is given by,

$$\begin{aligned} I_3 &= \frac{V}{R_3} \\ &= \frac{20}{5} = 4 \text{ A} \end{aligned}$$

Total current, $I = I_1 + I_2 + I_3 = 10 + 5 + 4 = 19 \text{ A}$

Therefore, the current through each resistor is 10 A, 5 A, and 4 A respectively and the total current is 19 A.

Question 3.5:

At room temperature (27.0°C) the resistance of a heating element is 100Ω . What is the temperature of the element if the resistance is found to be 117Ω , given that the temperature coefficient of the material of the resistor is $1.70 \times 10^{-4}^\circ\text{C}^{-1}$

Answer

Room temperature, $T = 27^\circ\text{C}$

Resistance of the heating element at T , $R = 100 \Omega$

Let T_1 is the increased temperature of the filament.

Resistance of the heating element at T_1 , $R_1 = 117 \Omega$

Temperature co-efficient of the material of the filament,

$$\alpha = 1.70 \times 10^{-4}^\circ\text{C}^{-1}$$

α is given by the relation,

$$\alpha = \frac{R_1 - R}{R(T_1 - T)}$$

$$T_1 - T = \frac{R_1 - R}{R\alpha}$$

$$T_1 - 27 = \frac{117 - 100}{100(1.7 \times 10^{-4})}$$

$$T_1 - 27 = 1000$$

$$T_1 = 1027^\circ\text{C}$$

Therefore, at 1027°C , the resistance of the element is 117Ω .

Question 3.6:

A negligibly small current is passed through a wire of length 15 m and uniform cross-section $6.0 \times 10^{-7} \text{ m}^2$, and its resistance is measured to be 5.0Ω . What is the resistivity of the material at the temperature of the experiment?

Answer

Length of the wire, $l = 15 \text{ m}$

Area of cross-section of the wire, $a = 6.0 \times 10^{-7} \text{ m}^2$

Resistance of the material of the wire, $R = 5.0 \Omega$

Resistivity of the material of the wire = ρ

Resistance is related with the resistivity as

$$R = \rho \frac{l}{A}$$

$$\rho = \frac{RA}{l}$$

$$= \frac{5 \times 6 \times 10^{-7}}{15} = 2 \times 10^{-7} \Omega \text{ m}$$

Therefore, the resistivity of the material is $2 \times 10^{-7} \Omega \text{ m}$.

Question 3.7:

A silver wire has a resistance of 2.1Ω at 27.5°C , and a resistance of 2.7Ω at 100°C . Determine the temperature coefficient of resistivity of silver.

Answer

Temperature, $T_1 = 27.5^\circ \text{C}$

Resistance of the silver wire at T_1 , $R_1 = 2.1 \Omega$

Temperature, $T_2 = 100^\circ \text{C}$

Resistance of the silver wire at T_2 , $R_2 = 2.7 \Omega$

Temperature coefficient of silver = α

It is related with temperature and resistance as

$$\alpha = \frac{R_2 - R_1}{R_1 (T_2 - T_1)}$$

$$= \frac{2.7 - 2.1}{2.1(100 - 27.5)} = 0.0039^\circ \text{C}^{-1}$$

Therefore, the temperature coefficient of silver is $0.0039^\circ \text{C}^{-1}$.

Question 3.8:

A heating element using nichrome connected to a 230 V supply draws an initial current of 3.2 A which settles after a few seconds to a steady value of 2.8 A. What is the steady temperature of the heating element if the room temperature is 27.0 °C? Temperature coefficient of resistance of nichrome averaged over the temperature range involved is $1.70 \times 10^{-4} \text{ } ^\circ\text{C}^{-1}$.

Answer

Supply voltage, $V = 230 \text{ V}$

Initial current drawn, $I_1 = 3.2 \text{ A}$

Initial resistance = R_1 , which is given by the relation,

$$\begin{aligned} R_1 &= \frac{V}{I} \\ &= \frac{230}{3.2} = 71.87 \text{ } \Omega \end{aligned}$$

Steady state value of the current, $I_2 = 2.8 \text{ A}$

Resistance at the steady state = R_2 , which is given as

$$R_2 = \frac{230}{2.8} = 82.14 \text{ } \Omega$$

Temperature co-efficient of nichrome, $\alpha = 1.70 \times 10^{-4} \text{ } ^\circ\text{C}^{-1}$

Initial temperature of nichrome, $T_1 = 27.0^\circ\text{C}$

Steady state temperature reached by nichrome = T_2

T_2 can be obtained by the relation for α ,

$$\alpha = \frac{R_2 - R_1}{R_1(T_2 - T_1)}$$

$$T_2 - 27 \text{ } ^\circ\text{C} = \frac{82.14 - 71.87}{71.87 \times 1.7 \times 10^{-4}} = 840.5$$

$$T_2 = 840.5 + 27 = 867.5 \text{ } ^\circ\text{C}$$

Therefore, the steady temperature of the heating element is 867.5°C

Question 3.9:

Determine the current in each branch of the network shown in fig 3.30:

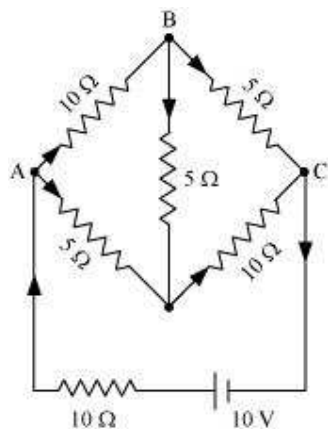

Answer

Current flowing through various branches of the circuit is represented in the given figure.

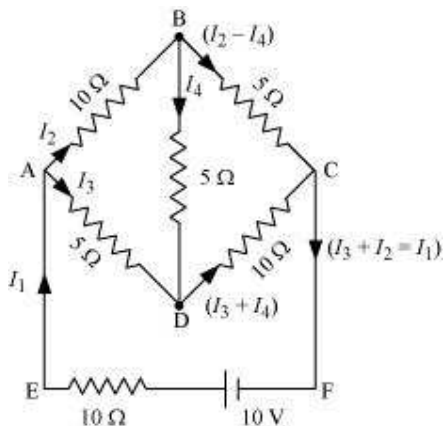

I_1 = Current flowing through the outer circuit

I_2 = Current flowing through branch AB

I_3 = Current flowing through branch AD

$I_2 - I_4$ = Current flowing through branch BC

$I_3 + I_4$ = Current flowing through branch CD

I_4 = Current flowing through branch BD

For the closed circuit ABDA, potential is zero i.e.,

$$10I_2 + 5I_4 - 5I_3 = 0$$

$$2I_2 + I_4 - I_3 = 0$$

$$I_3 = 2I_2 + I_4 \dots (1)$$

For the closed circuit BCDB, potential is zero i.e.,

$$5(I_2 - I_4) - 10(I_3 + I_4) - 5I_4 = 0$$

$$5I_2 + 5I_4 - 10I_3 - 10I_4 - 5I_4 = 0$$

$$5I_2 - 10I_3 - 20I_4 = 0$$

$$I_2 = 2I_3 + 4I_4 \dots (2)$$

For the closed circuit ABCFEA, potential is zero i.e.,

$$-10 + 10(I_1) + 10(I_2) + 5(I_2 - I_4) = 0$$

$$10 = 15I_2 + 10I_1 - 5I_4$$

$$3I_2 + 2I_1 - I_4 = 2 \dots (3)$$

From equations (1) and (2), we obtain

$$I_3 = 2(2I_3 + 4I_4) + I_4$$

$$I_3 = 4I_3 + 8I_4 + I_4$$

$$-3I_3 = 9I_4$$

$$-3I_4 = +I_3 \dots (4)$$

Putting equation (4) in equation (1), we obtain

$$I_3 = 2I_2 + I_4$$

$$-4I_4 = 2I_2$$

$$I_2 = -2I_4 \dots (5)$$

It is evident from the given figure that,

$$I_1 = I_3 + I_2 \dots (6)$$

Putting equation (6) in equation (1), we obtain

$$3I_2 + 2(I_3 + I_2) - I_4 = 2$$

$$5I_2 + 2I_3 - I_4 = 2 \dots (7)$$

Putting equations (4) and (5) in equation (7), we obtain

$$5(-2I_4) + 2(-3I_4) - I_4 = 2$$

$$-10I_4 - 6I_4 - I_4 = 2$$

$$17I_4 = -2$$

$$I_4 = \frac{-2}{17} \text{ A}$$

Equation (4) reduces to

$$I_3 = -3(I_4)$$

$$= -3\left(\frac{-2}{17}\right) = \frac{6}{17} \text{ A}$$

$$I_2 = -2(I_4)$$

$$= -2\left(\frac{-2}{17}\right) = \frac{4}{17} \text{ A}$$

$$I_2 - I_4 = \frac{4}{17} - \left(\frac{-2}{17}\right) = \frac{6}{17} \text{ A}$$

$$I_3 + I_4 = \frac{6}{17} + \left(\frac{-2}{17}\right) = \frac{4}{17} \text{ A}$$

$$I_1 = I_3 + I_2$$

$$= \frac{6}{17} + \frac{4}{17} = \frac{10}{17} \text{ A}$$

$$AB = \frac{4}{17} \text{ A}$$

Therefore, current in branch

$$\text{In branch BC} = \frac{6}{17} \text{ A}$$

$$\text{In branch CD} = \frac{-4}{17} \text{ A}$$

$$\text{In branch AD} = \frac{6}{17} \text{ A}$$

$$\text{In branch BD} = \left(\frac{-2}{17}\right) \text{ A}$$

$$\text{Total current} = \frac{4}{17} + \frac{6}{17} + \frac{-4}{17} + \frac{6}{17} + \frac{-2}{17} = \frac{10}{17} \text{ A}$$

Question 3.10:

(a) In a metre bridge [Fig. 3.27], the balance point is found to be at 39.5 cm from the end A, when the resistor Y is of 12.5Ω . Determine the resistance of X. Why are the connections between resistors in a Wheatstone or meter bridge made of thick copper strips?

(b) Determine the balance point of the bridge above if X and Y are interchanged.

(c) What happens if the galvanometer and cell are interchanged at the balance point of the bridge? Would the galvanometer show any current?

Answer

A metre bridge with resistors X and Y is represented in the given figure.

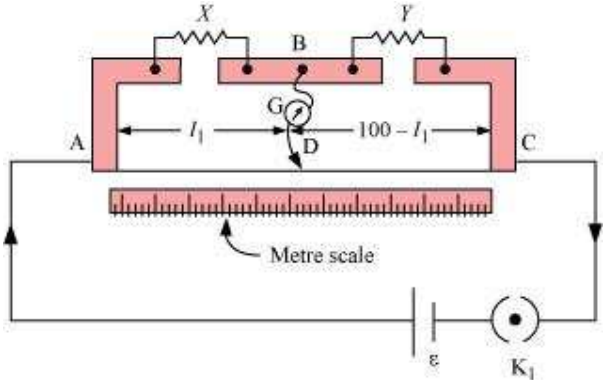

(a) Balance point from end A, $l_1 = 39.5$ cm

Resistance of the resistor $Y = 12.5 \Omega$

Condition for the balance is given as,

$$\frac{X}{Y} = \frac{100 - l_1}{l_1}$$

$$X = \frac{100 - 39.5}{39.5} \times 12.5 = 8.2 \Omega$$

Therefore, the resistance of resistor X is 8.2Ω .

The connection between resistors in a Wheatstone or metre bridge is made of thick copper strips to minimize the resistance, which is not taken into consideration in the bridge formula.

(b) If X and Y are interchanged, then l_1 and $100 - l_1$ get interchanged.

The balance point of the bridge will be $100 - l_1$ from A.

$$100 - l_1 = 100 - 39.5 = 60.5 \text{ cm}$$

Therefore, the balance point is 60.5 cm from A.

(c) When the galvanometer and cell are interchanged at the balance point of the bridge, the galvanometer will show no deflection. Hence, no current would flow through the galvanometer.

Question 3.11:

A storage battery of emf 8.0 V and internal resistance 0.5 Ω is being charged by a 120 V dc supply using a series resistor of 15.5 Ω . What is the terminal voltage of the battery during charging? What is the purpose of having a series resistor in the charging circuit?

Answer

Emf of the storage battery, $E = 8.0 \text{ V}$

Internal resistance of the battery, $r = 0.5 \Omega$

DC supply voltage, $V = 120 \text{ V}$

Resistance of the resistor, $R = 15.5 \Omega$

Effective voltage in the circuit = V^1

R is connected to the storage battery in series. Hence, it can be written as

$$V^1 = V - E$$

$$V^1 = 120 - 8 = 112 \text{ V}$$

Current flowing in the circuit = I , which is given by the relation,

$$I = \frac{V^1}{R+r}$$

$$= \frac{112}{15.5+5} = \frac{112}{16} = 7 \text{ A}$$

Voltage across resistor R given by the product, $IR = 7 \times 15.5 = 108.5 \text{ V}$

DC supply voltage = Terminal voltage of battery + Voltage drop across R

Terminal voltage of battery = $120 - 108.5 = 11.5 \text{ V}$

A series resistor in a charging circuit limits the current drawn from the external source.

The current will be extremely high in its absence. This is very dangerous.

Question 3.12:

In a potentiometer arrangement, a cell of emf 1.25 V gives a balance point at 35.0 cm length of the wire. If the cell is replaced by another cell and the balance point shifts to 63.0 cm, what is the emf of the second cell?

Answer

Emf of the cell, $E_1 = 1.25 \text{ V}$

Balance point of the potentiometer, $l_1 = 35 \text{ cm}$

The cell is replaced by another cell of emf E_2 .

New balance point of the potentiometer, $l_2 = 63 \text{ cm}$

The balance condition is given by the relation,

$$\frac{E_1}{E_2} = \frac{l_1}{l_2}$$
$$E_2 = E_1 \times \frac{l_2}{l_1}$$
$$= 1.25 \times \frac{63}{35} = 2.25 \text{ V}$$

Therefore, emf of the second cell is 2.25V.

Question 3.13:

The number density of free electrons in a copper conductor estimated in Example 3.1 is $8.5 \times 10^{28} \text{ m}^{-3}$. How long does an electron take to drift from one end of a wire 3.0 m long to its other end? The area of cross-section of the wire is $2.0 \times 10^{-6} \text{ m}^2$ and it is carrying a current of 3.0 A.

Answer

Number density of free electrons in a copper conductor, $n = 8.5 \times 10^{28} \text{ m}^{-3}$ Length of the copper wire, $l = 3.0 \text{ m}$

Area of cross-section of the wire, $A = 2.0 \times 10^{-6} \text{ m}^2$

Current carried by the wire, $I = 3.0 \text{ A}$, which is given by the relation,

$$I = nAeV_d$$

Where,

e = Electric charge = $1.6 \times 10^{-19} \text{ C}$

$$V_d = \text{Drift velocity} = \frac{\text{Length of the wire}(l)}{\text{Time taken to cover } l(t)}$$

$$I = nAe \frac{l}{t}$$

$$t = \frac{nAel}{I}$$

$$= \frac{3 \times 8.5 \times 10^{28} \times 2 \times 10^{-6} \times 1.6 \times 10^{-19}}{3.0}$$

$$= 2.7 \times 10^4 \text{ s}$$

Therefore, the time taken by an electron to drift from one end of the wire to the other is $2.7 \times 10^4 \text{ s}$.

Question 3.14:

The earth's surface has a negative surface charge density of 10^{-9} C m^{-2} . The potential difference of 400 kV between the top of the atmosphere and the surface results (due to the low conductivity of the lower atmosphere) in a current of only 1800 A over the entire globe. If there were no mechanism of sustaining atmospheric electric field, how much time (roughly) would be required to neutralise the earth's surface? (This never happens in practice because there is a mechanism to replenish electric charges, namely the continual thunderstorms and lightning in different parts of the globe). (Radius of earth = $6.37 \times 10^6 \text{ m}$.)

Answer

Surface charge density of the earth, $\sigma = 10^{-9} \text{ C m}^{-2}$

Current over the entire globe, $I = 1800 \text{ A}$

Radius of the earth, $r = 6.37 \times 10^6 \text{ m}$

Surface area of the earth,

$$A = 4\pi r^2$$

$$= 4\pi \times (6.37 \times 10^6)^2$$

$$= 5.09 \times 10^{14} \text{ m}^2$$

Charge on the earth surface,

$$q = \sigma \times A$$

$$= 10^{-9} \times 5.09 \times 10^{14}$$

$$= 5.09 \times 10^5 \text{ C}$$

Time taken to neutralize the earth's surface = t

$$\text{Current, } I = \frac{q}{t}$$

$$t = \frac{q}{I}$$

$$= \frac{5.09 \times 10^5}{1800} = 282.77 \text{ s}$$

Therefore, the time taken to neutralize the earth's surface is 282.77 s.

Question 3.15:

(a) Six lead-acid type of secondary cells each of emf 2.0 V and internal resistance 0.015Ω are joined in series to provide a supply to a resistance of 8.5Ω . What are the current drawn from the supply and its terminal voltage?

(b) A secondary cell after long use has an emf of 1.9 V and a large internal resistance of 380Ω . What maximum current can be drawn from the cell? Could the cell drive the starting motor of a car?

Answer

(a) Number of secondary cells, $n = 6$

Emf of each secondary cell, $E = 2.0 \text{ V}$

Internal resistance of each cell, $r = 0.015 \Omega$

series resistor is connected to the combination of cells.

Resistance of the resistor, $R = 8.5 \Omega$

Current drawn from the supply = I , which is given by the relation,

$$\begin{aligned} I &= \frac{nE}{R + nr} \\ &= \frac{6 \times 2}{8.5 + 6 \times 0.015} \\ &= \frac{12}{8.59} = 1.39 \text{ A} \end{aligned}$$

Terminal voltage, $V = IR = 1.39 \times 8.5 = 11.87 \text{ A}$

Therefore, the current drawn from the supply is 1.39 A and terminal voltage is 11.87 A.

(b) After a long use, emf of the secondary cell, $E = 1.9 \text{ V}$

Internal resistance of the cell, $r = 380 \Omega$

$$= \frac{E}{r} = \frac{1.9}{380} = 0.005 \text{ A}$$

Hence, maximum current

Therefore, the maximum current drawn from the cell is 0.005 A. Since a large current is required to start the motor of a car, the cell cannot be used to start a motor.

Question 3.16:

Two wires of equal length, one of aluminium and the other of copper have the same resistance. Which of the two wires is lighter? Hence explain why aluminium wires are

preferred for overhead power cables. ($\rho_{Al} = 2.63 \times 10^{-8} \Omega \text{ m}$, $\rho_{Cu} = 1.72 \times 10^{-8} \Omega \text{ m}$,
Relative density of Al = 2.7, of Cu = 8.9.)

Answer

Resistivity of aluminium, $\rho_{Al} = 2.63 \times 10^{-8} \Omega \text{ m}$

Relative density of aluminium, $d_1 = 2.7$

Let l_1 be the length of aluminium wire and m_1 be its mass.

Resistance of the aluminium wire = R_1

Area of cross-section of the aluminium wire = A_1

Resistivity of copper, $\rho_{Cu} = 1.72 \times 10^{-8} \Omega \text{ m}$

Relative density of copper, $d_2 = 8.9$

Let l_2 be the length of copper wire and m_2 be its mass.

Resistance of the copper wire = R_2

Area of cross-section of the copper wire = A_2

The two relations can be written as

$$R_1 = \rho_1 \frac{l_1}{A_1} \quad \dots (1)$$

$$R_2 = \rho_2 \frac{l_2}{A_2} \quad \dots (2)$$

It is given that,

$$R_1 = R_2$$

$$\rho_1 \frac{l_1}{A_1} = \rho_2 \frac{l_2}{A_2}$$

And,

$$l_1 = l_2$$

$$\therefore \frac{\rho_1}{A_1} = \frac{\rho_2}{A_2}$$

$$\frac{A_1}{A_2} = \frac{\rho_1}{\rho_2}$$

$$= \frac{2.63 \times 10^{-8}}{1.72 \times 10^{-8}} = \frac{2.63}{1.72}$$

Mass of the aluminium wire,

$$m_1 = \text{Volume} \times \text{Density}$$

$$= A_1 l_1 \times d_1 = A_1 l_1 d_1 \dots (3)$$

Mass of the copper wire,

$$m_2 = \text{Volume} \times \text{Density}$$

$$= A_2 l_2 \times d_2 = A_2 l_2 d_2 \dots (4)$$

Dividing equation (3) by equation (4), we obtain

$$\frac{m_1}{m_2} = \frac{A_1 l_1 d_1}{A_2 l_2 d_2}$$

For $l_1 = l_2$,

$$\frac{m_1}{m_2} = \frac{A_1 d_1}{A_2 d_2}$$

$$\text{For } \frac{A_1}{A_2} = \frac{2.63}{1.72},$$

$$\frac{m_1}{m_2} = \frac{2.63}{1.72} \times \frac{2.7}{8.9} = 0.46$$

It can be inferred from this ratio that m_1 is less than m_2 . Hence, aluminium is lighter than copper.

Since aluminium is lighter, it is preferred for overhead power cables over copper.

Question 3.17:

What conclusion can you draw from the following observations on a resistor made of alloy manganin?

Current A	Voltage V	Current A	Voltage V
0.2	3.94	3.0	59.2
0.4	7.87	4.0	78.8
0.6	11.8	5.0	98.6
0.8	15.7	6.0	118.5
1.0	19.7	7.0	138.2

2.0

39.4

8.0

158.0

Answer

It can be inferred from the given table that the ratio of voltage with current is a constant, which is equal to 19.7. Hence, manganin is an ohmic conductor i.e., the alloy obeys Ohm's law. According to Ohm's law, the ratio of voltage with current is the resistance of the conductor. Hence, the resistance of manganin is 19.7 Ω .

Question 3.18:

Answer the following questions:

(a) A steady current flows in a metallic conductor of non-uniform cross-section. Which of these quantities is constant along the conductor: current, current density, electric field, drift speed?

(b) Is Ohm's law universally applicable for all conducting elements?

If not, give examples of elements which do not obey Ohm's law.

(c) A low voltage supply from which one needs high currents must have very low internal resistance. Why?

(d) A high tension (HT) supply of, say, 6 kV must have a very large internal resistance. Why?

Answer

(a) When a steady current flows in a metallic conductor of non-uniform cross-section, the current flowing through the conductor is constant. Current density, electric field, and drift speed are inversely proportional to the area of cross-section. Therefore, they are not constant.

(b) No, Ohm's law is not universally applicable for all conducting elements. Vacuum diode semi-conductor is a non-ohmic conductor. Ohm's law is not valid for it.

(c) According to Ohm's law, the relation for the potential is $V = IR$

Voltage (V) is directly proportional to current (I).

R is the internal resistance of the source.

$$I = \frac{V}{R}$$

If V is low, then R must be very low, so that high current can be drawn from the source.

(d) In order to prohibit the current from exceeding the safety limit, a high tension supply must have a very large internal resistance. If the internal resistance is not large, then the current drawn can exceed the safety limits in case of a short circuit.

Question 3.19:

Choose the correct alternative:

- (a)** Alloys of metals usually have (greater/less) resistivity than that of their constituent metals.
- (b)** Alloys usually have much (lower/higher) temperature coefficients of resistance than pure metals.
- (c)** The resistivity of the alloy manganin is nearly independent of/increases rapidly with increase of temperature.
- (d)** The resistivity of a typical insulator (e.g., amber) is greater than that of a metal by a factor of the order of $(10^{22}/10^3)$.

Answer

- (a)** Alloys of metals usually have greater resistivity than that of their constituent metals.
- (b)** Alloys usually have lower temperature coefficients of resistance than pure metals.
- (c)** The resistivity of the alloy, manganin, is nearly independent of increase of temperature.
- (d)** The resistivity of a typical insulator is greater than that of a metal by a factor of the order of 10^{22} .

Question 3.20:

- (a)** Given n resistors each of resistance R , how will you combine them to get the (i) maximum (ii) minimum effective resistance? What is the ratio of the maximum to minimum resistance?
- (b)** Given the resistances of 1Ω , 2Ω , 3Ω , how will be combine them to get an equivalent resistance of (i) $(11/3) \Omega$ (ii) $(11/5) \Omega$, (iii) 6Ω , (iv) $(6/11) \Omega$?
- (c)** Determine the equivalent resistance of networks shown in Fig. 3.31.

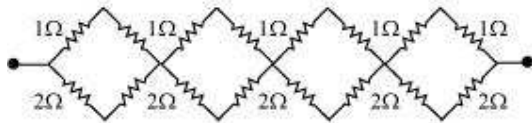

(a)

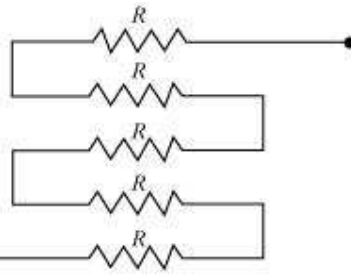

(b)

Answer

(a) Total number of resistors = n

Resistance of each resistor = R

(i) When n resistors are connected in series, effective resistance R_1 is the maximum, given by the product nR .

Hence, maximum resistance of the combination, $R_1 = nR$

(ii) When n resistors are connected in parallel, the effective resistance (R_2) is the

$$\frac{R}{n}$$

minimum, given by the ratio n .

$$\frac{R}{n}$$

Hence, minimum resistance of the combination, $R_2 = \frac{R}{n}$

(iii) The ratio of the maximum to the minimum resistance is,

$$\frac{R_1}{R_2} = \frac{nR}{\frac{R}{n}} = n^2$$

(b) The resistance of the given resistors is,

$$R_1 = 1 \Omega, R_2 = 2 \Omega, R_3 = 3 \Omega$$

$$R' = \frac{11}{3} \Omega$$

i. Equivalent resistance,

Consider the following combination of the resistors.

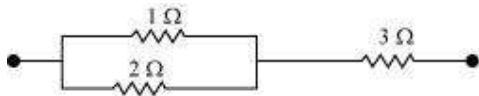

Equivalent resistance of the circuit is given by,

$$R' = \frac{2 \times 1}{2 + 1} + 3 = \frac{2}{3} + 3 = \frac{11}{3} \Omega$$

$$R' = \frac{11}{5} \Omega$$

ii. Equivalent resistance,

Consider the following combination of the resistors.

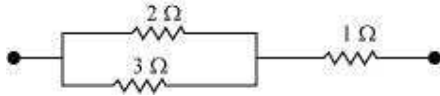

Equivalent resistance of the circuit is given by,

$$R' = \frac{2 \times 3}{2 + 3} + 1 = \frac{6}{5} + 1 = \frac{11}{5} \Omega$$

(iii) Equivalent resistance, $R' = 6 \Omega$

Consider the series combination of the resistors, as shown in the given circuit.

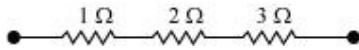

Equivalent resistance of the circuit is given by the sum,

$$R' = 1 + 2 + 3 = 6 \Omega$$

(iv) Equivalent resistance, $R' = \frac{6}{11} \Omega$

Consider the series combination of the resistors, as shown in the given circuit.

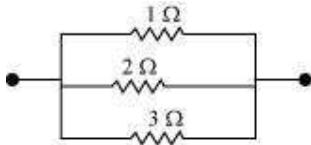

Equivalent resistance of the circuit is given by,

$$R' = \frac{1 \times 2 \times 3}{1 \times 2 + 2 \times 3 + 3 \times 1} = \frac{6}{11} \Omega$$

(c) (a) It can be observed from the given circuit that in the first small loop, two resistors of resistance 1 Ω each are connected in series.

Hence, their equivalent resistance = $(1 + 1) = 2 \Omega$

It can also be observed that two resistors of resistance 2 Ω each are connected in series.

Hence, their equivalent resistance = $(2 + 2) = 4 \Omega$.

Therefore, the circuit can be redrawn as

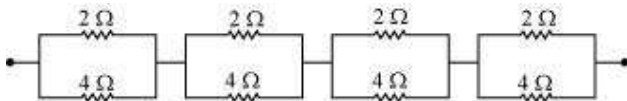

It can be observed that $2\ \Omega$ and $4\ \Omega$ resistors are connected in parallel in all the four loops. Hence, equivalent resistance (R') of each loop is given by,

$$R' = \frac{2 \times 4}{2 + 4} = \frac{8}{6} = \frac{4}{3}\ \Omega$$

The circuit reduces to,



All the four resistors are connected in series.

$$\frac{4}{3} \times 4 = \frac{16}{3}\ \Omega$$

Hence, equivalent resistance of the given circuit is

(b) It can be observed from the given circuit that five resistors of resistance R each are connected in series.

Hence, equivalent resistance of the circuit = $R + R + R + R + R$

$$= 5R$$

2

Question 3.21:

Determine the current drawn from a 12 V supply with internal resistance $0.5\ \Omega$ by the infinite network shown in Fig. 3.32. Each resistor has $1\ \Omega$ resistance.

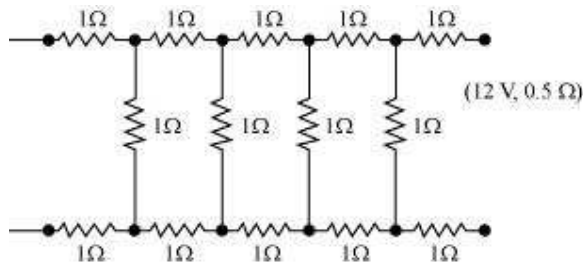

Answer

The resistance of each resistor connected in the given circuit, $R = 1\ \Omega$

Equivalent resistance of the given circuit = R'

The network is infinite. Hence, equivalent resistance is given by the relation,

$$\therefore R' = 2 + \frac{R'}{R' + 1}$$

$$(R')^2 - 2R' - 2 = 0$$

$$R' = \frac{2 \pm \sqrt{4+8}}{2}$$
$$= \frac{2 \pm \sqrt{12}}{2} = 1 \pm \sqrt{3}$$

Negative value of R' cannot be accepted. Hence, equivalent resistance,

$$R' = (1 + \sqrt{3}) = 1 + 1.73 = 2.73 \Omega$$

Internal resistance of the circuit, $r = 0.5 \Omega$

Hence, total resistance of the given circuit = $2.73 + 0.5 = 3.23 \Omega$

Supply voltage, $V = 12 \text{ V}$

According to Ohm's Law, current drawn from the source is given by the ratio, $\frac{12}{3.23} = 3.72 \text{ A}$

Question 3.22:

Figure 3.33 shows a potentiometer with a cell of 2.0 V and internal resistance 0.40Ω maintaining a potential drop across the resistor wire AB. A standard cell which maintains a constant emf of 1.02 V (for very moderate currents up to a few mA) gives a balance point at 67.3 cm length of the wire. To ensure very low currents drawn from the standard cell, a very high resistance of $600 \text{ k}\Omega$ is put in series with it, which is shorted close to the balance point. The standard cell is then replaced by a cell of unknown emf ϵ and the balance point found similarly, turns out to be at 82.3 cm length of the wire.

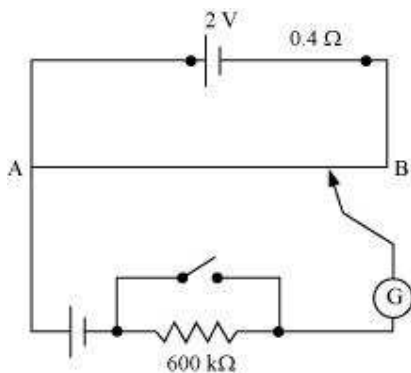

- (a) What is the value ε ?
- (b) What purpose does the high resistance of $600 \text{ k}\Omega$ have?
- (c) Is the balance point affected by this high resistance?
- (d) Is the balance point affected by the internal resistance of the driver cell?
- (e) Would the method work in the above situation if the driver cell of the potentiometer had an emf of 1.0 V instead of 2.0 V ?
- (f) Would the circuit work well for determining an extremely small emf, say of the order of a few mV (such as the typical emf of a thermo-couple)? If not, how will you modify the circuit?

Answer

(a) Constant emf of the given standard cell, $E_1 = 1.02 \text{ V}$

Balance point on the wire, $l_1 = 67.3 \text{ cm}$

A cell of unknown emf, ε , replaced the standard cell. Therefore, new balance point on the wire, $l = 82.3 \text{ cm}$

The relation connecting emf and balance point is,

$$\frac{E_1}{l_1} = \frac{\varepsilon}{l}$$

$$\varepsilon = \frac{l}{l_1} \times E_1$$

$$= \frac{82.3}{67.3} \times 1.02 = 1.247 \text{ V}$$

The value of unknown emfis 1.247 V .

(b) The purpose of using the high resistance of $600 \text{ k}\Omega$ is to reduce the current through the galvanometer when the movable contact is far from the balance point.

- (c) The balance point is not affected by the presence of high resistance.
- (d) The point is not affected by the internal resistance of the driver cell.
- (e) The method would not work if the driver cell of the potentiometer had an emf of 1.0 V instead of 2.0 V. This is because if the emf of the driver cell of the potentiometer is less than the emf of the other cell, then there would be no balance point on the wire.
- (f) The circuit would not work well for determining an extremely small emf. As the circuit would be unstable, the balance point would be close to end A. Hence, there would be a large percentage of error.

The given circuit can be modified if a series resistance is connected with the wire AB. The potential drop across AB is slightly greater than the emf measured. The percentage error would be small.

Question 3.23:

Figure 3.34 shows a potentiometer circuit for comparison of two resistances. The balance point with a standard resistor $R = 10.0 \Omega$ is found to be 58.3 cm, while that with the unknown resistance X is 68.5 cm. Determine the value of X . What might you do if you failed to find a balance point with the given cell of emf ϵ ?

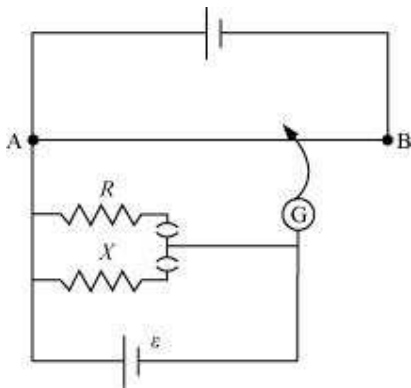

Answer

Resistance of the standard resistor, $R = 10.0 \Omega$

Balance point for this resistance, $l_1 = 58.3 \text{ cm}$

Current in the potentiometer wire = i

Hence, potential drop across R , $E_1 = iR$

Resistance of the unknown resistor = X

Balance point for this resistor, $l_2 = 68.5 \text{ cm}$

Hence, potential drop across X , $E_2 = iX$

The relation connecting emf and balance point is,

$$\frac{E_1}{E_2} = \frac{l_1}{l_2}$$

$$\frac{iR}{iX} = \frac{l_1}{l_2}$$

$$X = \frac{l_1}{l_2} \times R$$

$$= \frac{68.5}{58.3} \times 10 = 11.749 \Omega$$

Therefore, the value of the unknown resistance, X , is 11.75 Ω .

If we fail to find a balance point with the given cell of emf, ϵ , then the potential drop across R and X must be reduced by putting a resistance in series with it. Only if the potential drop across R or X is smaller than the potential drop across the potentiometer wire AB, a balance point is obtained.

Question 3.24:

Figure 3.35 shows a 2.0 V potentiometer used for the determination of internal resistance of a 1.5 V cell. The balance point of the cell in open circuit is 76.3 cm. When a resistor of 9.5 Ω is used in the external circuit of the cell, the balance point shifts to 64.8 cm length of the potentiometer wire. Determine the internal resistance of the cell.

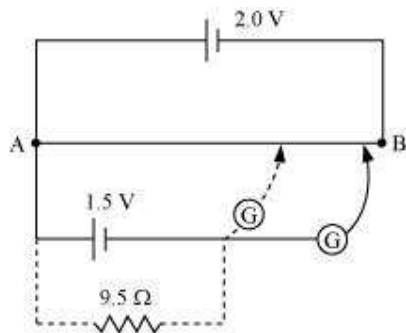

Answer

Internal resistance of the cell = r

Balance point of the cell in open circuit, $l_1 = 76.3$ cm

An external resistance (R) is connected to the circuit with $R = 9.5 \Omega$

New balance point of the circuit, $l_2 = 64.8 \text{ cm}$

Current flowing through the circuit = I

The relation connecting resistance and emf is,

$$r = \left(\frac{l_1 - l_2}{l_2} \right) R$$
$$= \frac{76.3 - 64.8}{64.8} \times 9.5 = 1.68 \Omega$$

Therefore, the internal resistance of the cell is 1.68Ω .